



### Designation

NCE EI 32 - 60 / 180



### Construction

Energy saving variable speed circulating pump driven by a permanent magnet synchronous motor (pm) controlled by on board inverter.

### Applications

- Small domestic heating systems.
- Floor heating systems.
- Air conditioning systems.

### Technical data

- Liquid temperature from +2 °C to +95 °C
- Ambient temperature from 0 °C to +40 °C
- Maximum permissible working pressure: 6 bar
- Storage: -20°C/+70°C max. relative humidity 95% at 40 °C
- Certifications: in conformity with CE requirements
- Sound pressure ≤ 43 dB (A).
- Minimum suction pressure: 0,5 bar at 95 °C
- Maximum glycol quantity: 40%
- EMC according to: EN 55014-1, EN 61000-3-2, EN 55014-2
- Connections: threaded ports ISO 228: G 1, G 1 1/2, G 2
- The benchmark for most efficient circulators is EEI ≤ 0,20.

### Motor

Synchronous motor with permanent magnet.

- Motor: variable speed
- Standard voltage: single-phase 230 V (-10%;+6%)
- Frequency: 50 Hz
- Protection: IP 44
- Insulation class: H
- Class II appliance
- Overload protection (jammed rotor):
  - 1) automatic protection with electronic rotor release
  - 2) Overload thermal protector
- Cable: phases and neutral
- Constructed in accordance with: EN 60335-1, EN 60335-2-51.

### Special features on request

Brass or cast iron unions.

## Features

### Compact design

The space saving **NCE EI** is the most compact circulating pump in the Calpeda range, and is amongst one of the most compact circulating pumps on the market today. This allows for easy installation in small domestic heating systems.

### Easy to install and to adjust

Installing the **NCE EI** is considerably simplified by the quick setting and power installation plug. The adjustment is simple and intuitive thanks to the ability to be able to select the optimum working point or mode via a simple LED indicator and switch.

### Reliability

Like all our electronic circulating pumps, the **NCE EI** features the patented self-cleaning square chamber design, which eliminates any possibility of rotor blockage.

Ceramic shaft

Hydraulics components are completely painted with cataphoresis

### Easy use

Operating range with fixed curves from 2 m to 6 m; possibility to choose proportional pressure curve and 2 constant pressure curves. Selection of the optimum working point.

### Patented

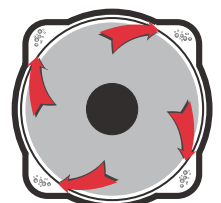

Escape routes for impurities inside the rotor chamber

### Operating modes



#### MANUAL PROGRAMMING

(BLUE LED)

Setting the switch at any position between the MIN and MAX points will allow the pump to operate on fixed performance curves (classic form of Q/H).

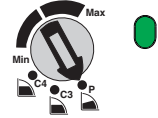

#### PROPORTIONAL CURVE PROGRAMMING $\Delta p-v$

(GREEN LED)

Moving the switch to the 'P' setting will allow the pump to operate against a proportional performance curve. This feature ensures maximum energy efficiency.

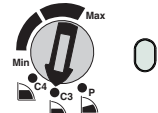

#### CONSTANT CURVE PROGRAMMING $\Delta p-c$ 3 m

(WHITE LED)

Moving the switch to the 'C' setting will allow the pump to operate against a constant performance curve (ideal for flow rates lower to 2 m<sup>3</sup>/h).

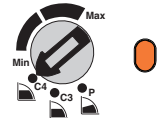

#### CONSTANT CURVE PROGRAMMING $\Delta p-c$ 4 m

(ORANGE LED)

Moving the switch to the 'C' setting will allow the pump to operate against a constant performance curve (ideal for flow rates lower to 1.7 m<sup>3</sup>/h).

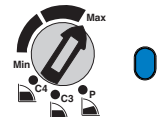

#### WARNING!

The red LED indicates that the pump is not rotating but is still under tension.

### Characteristic curves

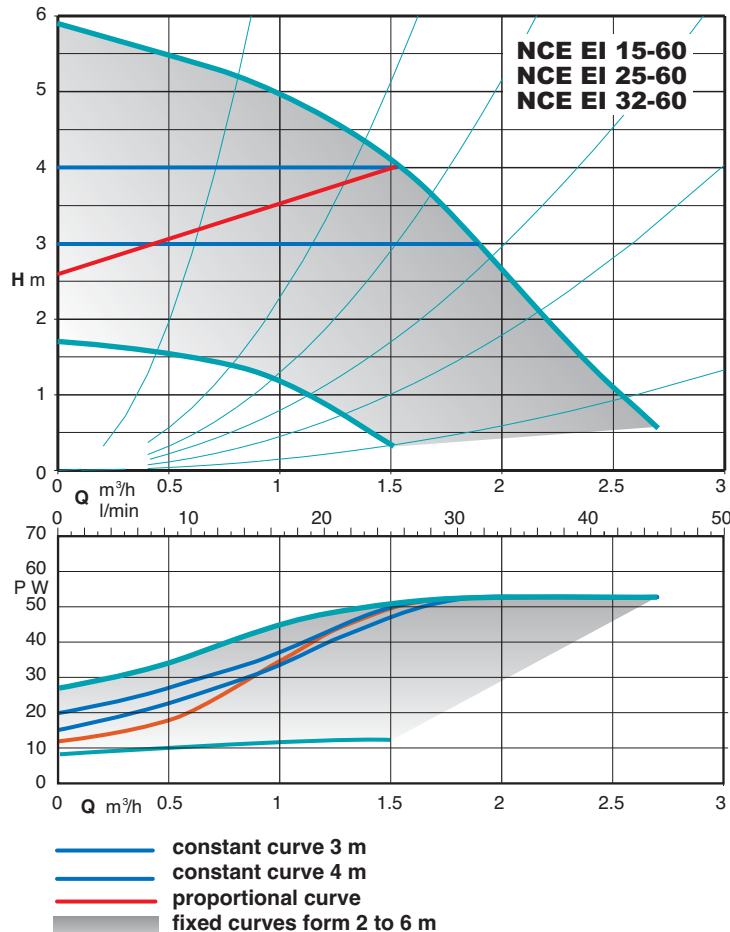

### Materials

| Component       | Pos. | Material                  |
|-----------------|------|---------------------------|
| Pump casing     | 1    | Cast iron GJL 200 EN 1561 |
| Impeller        | 2    | Composite                 |
| Shaft           | 3    | Ceramic                   |
| Bearings        | 4    | Carbon                    |
| Thrust bearing  | 5    | Ceramic                   |
| Rotor           | 6    | Composite / Ferrite       |
| Winding         | 7    | Copper wire               |
| Electronic card | 8    | -                         |
| Gasket          | 9    | EPDM                      |

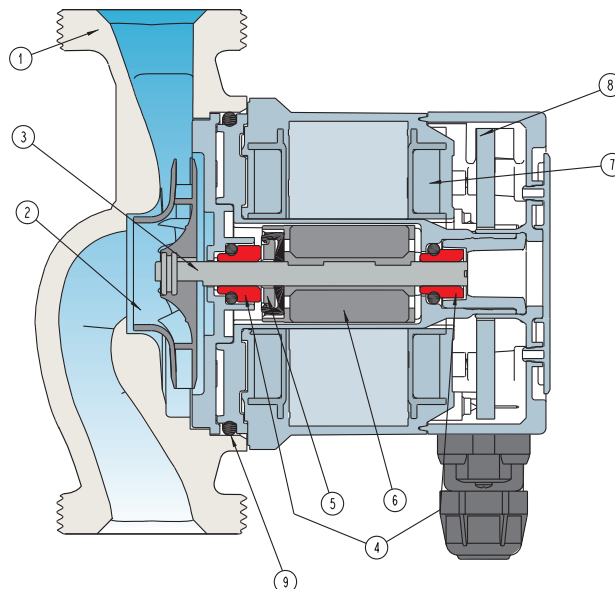

### Dimensions and weights

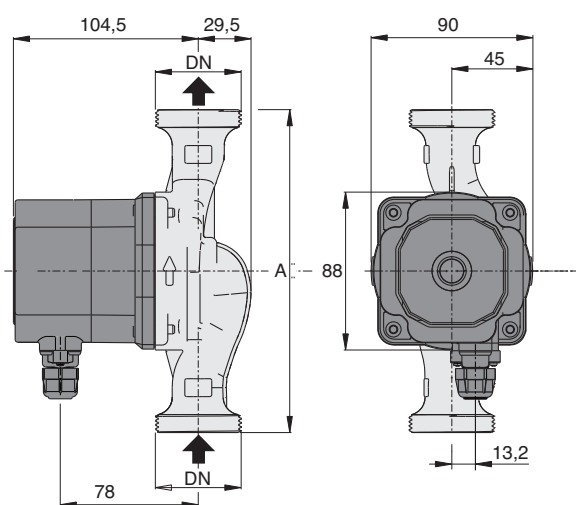

Unions (on request)

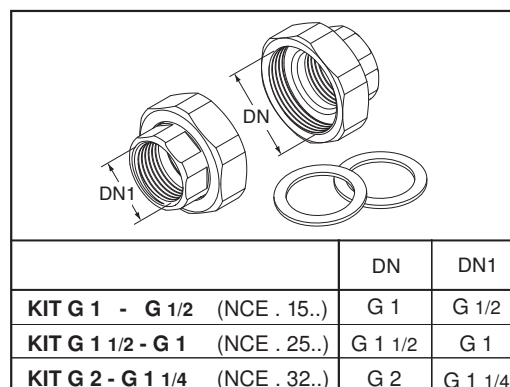

| TYPE                    | DN      | 230V  |       | P1    |       | mm<br>A | Peso<br>netto<br>kg |
|-------------------------|---------|-------|-------|-------|-------|---------|---------------------|
|                         |         | A max | A min | W max | W min |         |                     |
| <b>NCE EI 15-60/130</b> | G 1     | 0,40  | 0,08  | 53    | 8,4   | 130     | 1,70                |
| <b>NCE EI 25-60/130</b> | G 1 1/2 | 0,40  | 0,08  | 53    | 8,4   | 130     | 2,05                |
| <b>NCE EI 25-60/180</b> | G 1 1/2 | 0,40  | 0,08  | 53    | 8,4   | 180     | 2,20                |
| <b>NCE EI 32-60/180</b> | G 2     | 0,40  | 0,08  | 53    | 8,4   | 180     | 2,33                |

### Examples of installations

#### Installation

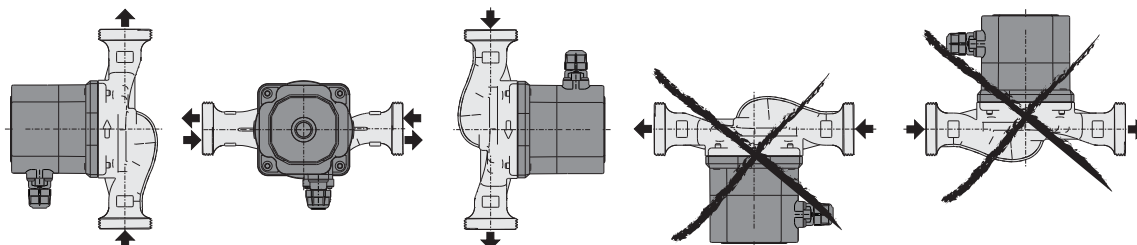

#### Terminal box arrangement (on request)

